

WOODSIDE PLANTATION

Inside:

- Common Area Landscaping
- ARB A Decade of "Making a Difference in Woodside"
- ARB Activity
- Treasurer's Report
- Development Company
- ARB
- Covenants
- Board Meeting Minutes

Board Meeting Dates

- December 21

All meetings are held on the third Monday at 3:00 p.m., at the Property Owners' Office (except where noted).

WPPOA
Holiday Hours

Closed December 24th
and 25th, 31st and
January 1st

Happy Holidays

WPPOA BOARD OF DIRECTORS



Back (Left to Right): Larry Wittenmyer, Dan Franck, Greg Hoffman, Linda Rudd, Dave Rodgers
Front: Lynette Brumfield, John Rogers, Mary Shultz
Not Pictured: Greg Burkes

PRESRT-STD
 U.S. POSTAGE
PAID
 Augusta, Ga
 Permit No. 545

WOODSIDE PLANTATION
 PROPERTY OWNERS' ASSOCIATION
 1411 Silver Bluff Road | Aiken, South Carolina 29803



President's Remarks | Larry Wittenmyer

As the Holiday season approaches, we all get involved in parties and other gatherings to celebrate. This is also the time of year that your Board engages in several year-end duties. One of those is developing next year's budget and sending out assessment notices to all property owners. By the time you read this, you should have received your notice, by mail. If not, please notify the WPPOA office to request a duplicate. During the Holidays, many of you decorate the outside of your homes with festive lights, etc. Please be careful when putting up or taking

down these decorations, as there's nothing worse than being injured during this otherwise happy time of

Please remember that our covenants require that all holiday lighting and decorations be removed in a timely period after the New Year.

the year. Also, please remember that our covenants require that all holiday lighting and decorations be removed in a timely period after the New Year.

While I'm on the topic of safety, if you haven't already done so, be sure to check and replace your smoke detector batteries. With all of the extra lights, festive fireplace activity and combustible items like Christmas trees in our homes this is the season of increased house fire danger. It's a proven fact that smoke detectors save lives!

Lastly, I want to thank all of the Board members and the WPPOA staff for another productive year! I also wish all of you property owners a very Happy Holiday and a safe and healthy New Year.!

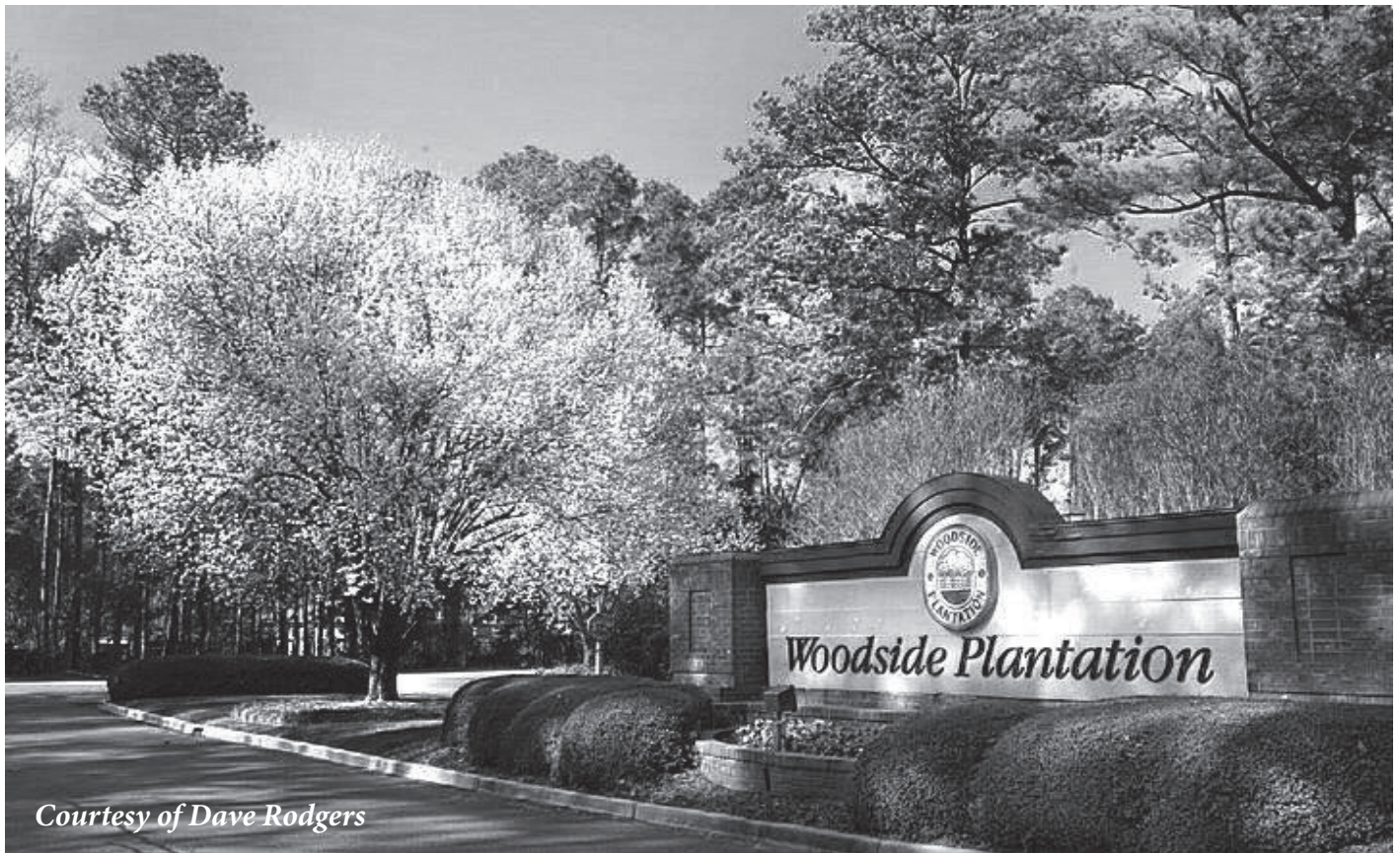

Courtesy of Dave Rodgers

Common Area Landscaping | *Mary H. Shultz*

WHAT'S HAPPENING

Spring:

For 8 out of the past 10 years, South Carolina has been in a drought situation. Due to all of the recent rainfall, South Carolina may be out of drought conditions; however, with the rise in the water table, other issues are now evident. Springs are springing forth. A major issue is being resolved along Woodside Plantation Drive between Winged Elm and Cottonwood. A new drainage system stretching over 1,000 feet and comprised of solid pipes and French drains is being installed to handle the spring water flowing down and across the street. Another spring also caused the walking path to collapse close to Summer Squall Lane. Repairs are being pursued.

2016 Landscaping Budget Finalized.

The Board approved the landscaping budget for 2016 at \$631,000 to pay for scheduled contracted work and unscheduled maintenance, irrigation repairs, electricity, water, the garden plot area, apportioned salaries for POA staff, Firewise, and mowing of the vacant lots. This represents an increase of \$31,000 from the 2015 budget. The increase is driven mainly by the following: (1) the addition of new areas to POA responsibility; (2) budgeting for additional lime application and aeration to promote improved soil health; (3) Firewise; and (4) repair of several areas that require either sod or ground cover. In the January article, I will provide the 2015 actual costs incurred in each cited line item vs the 2015 and 2016 budgets for each item.

The approved 2016 budget for special projects is \$46,375, a reduction of \$12,605 from the 2015 budget of \$58,980. Special projects include step

replacement at the gardens; replacement of trees and bushes removed and /or damaged by the ice storm and tornado, pruning of trees along our roadways, and replacement of some aged plantings. Specific details will be itemized in future editions of the newsletter.

Deer Control Tip:

At this time of year, the deer are looking for their winter feeding grounds, and making a list of the best "restaurants" in town. According to the Aiken Master Gardener Association, Milorganite, (an inexpensive fertilizer), is frequently used as a deer repellent by gardeners, farmers, and nurseries and does not break down as fast as liquid repellents. Spread it around your flower beds and trees and on top of your pine straw. If you are using other deer control products, be sure to continue using them throughout the winter. Remember, when the deer can no longer smell the repellents, they will return in a heartbeat.

Holiday Safety:

Yes, the holidays are here, and Christmas trees, lights, and candles will soon be everywhere, while celebrations and family gatherings commence, and guests fill our homes to celebrate the season. As a result, some added caution should be taken. According to a National Fire Protection Association (NFPA) report, U.S. fire departments responded to more than 200 home structure fires annually from 2002 to 2005 that began with Christmas trees. Each year fires occurring during the holiday season injure 2,600 individuals and cause over \$930 million in damage, according to the United States Fire Administration. Electrical failures or malfunctions were involved in nearly half of the fires, while nearly a quarter

occurred because a heat source was located too close to the tree. Decorative lights with live voltage were involved in more than 20 percent of the instances. Electrical malfunctions can also ignite artificial trees and homeowners should take the same precautions in terms of tree placement and decorations as they would with a real tree.

1. If you are using a fresh tree, choose a tree with fresh, green needles that do not fall off when touched.
2. Before placing the tree in the stand, cut 1" to 2" from the base of the trunk.
3. Make sure the tree (real or artificial) is at least 3 feet away from any heat source.
4. Add water to the tree daily.
5. While extension cords are a convenient way to supply power right where you need it for your holiday decorations, they can also create hazards if not used safely.
6. Use lights that have the label of an independent testing laboratory. Some lights are only for indoor or outdoor use, but not both.
7. Replace any string of lights with worn or broken cords or loose bulb connections. Connect no more than three strands of mini string sets and a maximum of 50 bulbs for screw-in bulbs. Read manufacturer's instructions for number of LED strands to connect.
8. Always turn off Christmas tree lights before leaving home or going to bed.
9. Get rid of the tree when it begins dropping needles. Dried-out trees are a fire danger and should not be left in the home or garage, or placed outside against the home. According to the NFPA even a well-watered tree should be taken down after four weeks.

In closing, I wish all of you a safe, healthy, and peaceful holiday season. Merry Christmas and Happy New Year! 🍷

ARB | *Dave Rodgers*

A Decade of Making a Difference in Woodside

After almost 11 years of dedicated service on the ARB Board, Chuck Martini has decided to take a well-deserved break. Chuck started on the ARB conducting building site inspections and within 6 months moved onto leading the ARB activities related to new construction lot clearing and property owner requests for tree removal and satellite dish installation.

Chuck is proud to be a Woodside resident and he showed it by Making a Difference - for a decade. He took his Board responsibilities seriously and, for 10+ years has been a valued community resource and committed Board member.



Chuck Martini recognized by ARB Director Dave Rodgers

Making a Difference

In recognition of ten years of dedicated volunteer service selflessly given to the WPPOA Architectural Review Board.

Your consistent adherence to and promotion of WPPOA principals, high integrity, candor, and can-do attitude is greatly appreciated and acknowledged by the Board and the community.

CHUCK MARTINI

Many want to make a difference. A few just do it.

November 2015

ARB Activity | *November, 2015*

Building and Environmental Inspections.....	34	Policy.....	1
Homeowner Issues.....	4	Satellite Dish Location Requests.....	5
Improvements.....	14	Tree Removal Requests.....	20
Landscape Plans.....	6		

Please remember that ARB approval is required for Satellite Dishes and Tree Removal PRIOR to scheduling your vendors.

Treasurer's Report | December, 2015 | Lynette Brumfield

Since I was elected in September and became Treasurer of the Board, my primary responsibility has been working with the Directors on the 2016 budget. The Board had been engaged in ongoing discussions about the budget since August. The final changes and updates to the 2016 budget were completed and approved at the November Board meeting of the. The budget requires a 5.2% increase in annual assessments to \$810 for dwellings and \$405 for unimproved lots. It also includes a 15% contribution to the Designated Reserve Fund.

There were several items added to the budget in order to maintain, repair and improve the overall conditions of the Plantation, which include:

- Wooden bridge inspections.
- Walking path repairs.
- Firewise expenditures (we have applied for a grant which may offset the costs)

The final changes and updates to the 2016 budget were completed and approved at the November meeting of the Board.

- Resident directory printing and mailing (last directory printed in October 2014).
- Security man hours increased at the Village gate.
- Ridge Oaks, Pine Glen, and Twin Ponds sections transitioned to the POA from the development company.
- Bi-annual inspection of Holley, Burden, Royal, Oakman and Magnolia Lakes.
- Continued landscaping replacements due to the ice storm and tornado damage.

The annual assessment notices will be mailed this month with a copy of the 2016 budget. Final assessment payment is due by March 1, 2016 without penalty. If you have not received your assessment notice by the end of December, please contact the POA office for a duplicate.

Have a happy and safe holiday season and I will see you around the Plantation. 

Development Company | Diana Peters

Welcome to AnShu Asian Café!

The Village at Woodside is pleased to announce that AnShu Asian Café is preparing to open the doors of their new location in The Village this month! Specializing in gourmet Asian-fusion style fare, fresh sushi and a full bar, AnShu Asian Café will bring an enticing new dining option right to your back door.

Be on the lookout for further information about dates and a special preview opening for Woodside Plantation residents. In the meantime, feel free to check out the website at www.anshuasiancafe.com

*AnShu Asian
Café will bring
an enticing new
dining option
right to your
back door.*

**FIREWISE VOLUNTEERS
ARE NEEDED FOR EFFORTS
STARTING IN JANUARY.**

If you enjoy working outdoors and would like to participate in the Firewise initiative, please call:

Steve Powell: 803-514-2409 or
John Carman: 757-759-2395

*Special Thanks to
The Reserve Club for
providing meals to our
Security Guards on
Thanksgiving Day!*

Welcome new residents!

- **Lucy Bureau & Robert Warner**
112 Yellow Pine Road
- **David & Kathy Cruse**
109 Poplar Hill Court
- **Donald & Norena Dennison**
221 Summer Winds Circle
- **Gary Lloyd & Rose Maccio**
243 Summer Winds Circle

- **Bruce & Georgia Leinster**
187 Highland Reserve Court
- **Rodney & Beverly Richards**
109 Cameron Alley
- **Dean & Patricia Wittwer**
413 Spalding Lake Circle

Summary of Complaints

November, 2015

Debris	1
Pet.....	1
Unsightly conditions.....	6
ARB	2
Common Area.....	6
Roads & Walking Paths.....	1
Security	4
Total complaints	21

The Blotter | *October, 2015*

Alarms.....	0	Parking.....	0
Decal/Pass Violation.....	0	Suspicious Condition/ Person	2
Emergency Vehicles/ Public Safety	75	Traffic violations	0**
Fishing.....	0	Vandalism.....	2
Gate Maintenance	0		
Landscaping.....	0		
Light Maintenance.....	2		

***This does not include the numerous citations issued by Aiken Department of Public Safety.*

Covenants | *Linda Rudd*

I don't know about you, but it seems like we just took down the Christmas decorations a few weeks ago and now all those trees, bows, balls, snowmen and Santa Claus are out of the boxes again in time for holiday celebrations for another year. For those of us used to a frigid Christmas, warm temps take a little getting used to. We are happy to be here rather than shivering, slipping and sliding in more frigid climates. There are two things I would like to mention this month which come together in the end. First, since December is traditionally a time to decorate, many of our neighbors are determined to dazzle us with lots of color, lights, wreaths, and garlands with big red bows. While decorations can range from a simple bow on a mail box to lights draped around the yard in an explosive display of spirit, ENJOY IT! Make a point to take friends or family out after dark to enjoy the displays our neighbors have worked so hard at putting up for everyone's enjoyment. There is something about the festive presentation that makes most of us feel very grateful for where we live, how we live, and the warm spirit of the season. This

While decorations can range from a simple bow on a mail box to lights draped around the yard in an explosive display of spirit, ENJOY IT!

brings me to the second point I'd like to share. This season is not happy for many people. Holidays such as Christmas can be very stressful for a variety of reasons. Loss of family or close friends, high expectations that cannot be met and therefore bring disappointment, poor health and financial challenges all can cause depression and stress which are very detrimental to basic physical and mental health. Some of the complaints or concerns I receive in Covenants could possibly be addressed

between neighbors with kindness and an offer to help. I have one right now that concerns the yard of an ill property owner who is unable neither to do basic maintenance nor to pay for it. This is rare in Woodside but it happens. The POA could pay for it and bill the property owner and the money would most likely never be recouped to

the general fund. This is an extreme case but there are other situations where we can help each other by being a better neighbor and friend. That is the gift we can give each other in this glorious holiday season! ❖



OFFICER OF THE MONTH

Angela Poe

Our Officer of the Month for December is Angela Poe. Angela has been a familiar face at The Anderson Pond Gate since 2009. She is happily married to her husband of 16 years. Angela rescues animals and has a small menagerie of cats, dogs, and ducks. Recently she has ventured out of the city for the peace and quiet of the forest. She enjoys watching the birds that come to her feeders. The only thing Officer Poe misses about living in town is the unlimited high-speed internet.

Please be sure to stop and say hello to Angela next time you see her! She is sure to brighten your day with her quick wit and refreshing humor.



WOODSIDE PLANTATION PROPERTY OWNERS ASSOCIATION, INC. Board Meeting

November 16th, 2015

Meeting was called to order by Larry Wittenmyer at 3:03 pm at the Woodside POA office conference room and a quorum was established.

Attendees:

Larry Wittenmyer, *President*

Mary Shultz, *Vice president*

Lynette Brumfield, *member*

Greg Burkes, *member*

Dan Franck, *member*

Diana Peters, *Development Company*

Dave Rodgers, *member*

John Rogers, *member*

Linda Rudd, *member*

Greg Hoffman, *member*

Stephanie Wood, *association manager*

Guest: Mr. Marc Bell, Nicholas Tolerico, Coach and Patty Abshire

Approval of Minutes:

There being no additions or corrections, the minutes of the October 19th, 2015 board meeting stand approved as written.

President's Comments:

President Larry Wittenmyer informed the Board that the placement of the septic tank at the Village gate guard facility is complete and as a result the guards can remain at the gatehouse to effectively and efficiently manage the gate.

Resident Comments: Mr. Tolerico offered his suggestions as to budgeting for future road repaving.

Reports and Motions:

Lynette Brumfield our Treasurer presented to the Board the 2016 budget for approval. The Budget was approved unanimously.

Diana Peters updated on the Board on property transfers to the Association and the status of new restaurants in the Village.

Linda Rudd on Covenants continues to work on her efforts to educate residents on the risk associated with feeding the deer.

Mary Shultz updated us on plantings, the treatment of rye grass, and the deer survey. Again, the Board is appreciative of the high rate of participation in our survey and all the helpful comments. She is also involved in investigating landslides in the Winged Elm area, due to water on the hillside possibly from underground springs. She also proposed resolving issues associated with spring water running across the road at Woodside Plantation Drive between Winged Elm and Cottonwood. A French drain will need to be installed to take the water to the storm drain.

Greg Hoffman continues his inspection of the many miles of fence that protects and enhances our community. Virtually all of this must be done by foot.

John Rogers, updated the Board on the status of the walking path on Woodside Plantation Drive at the intersection of Summer Squall. Sinkholes had formed in several locations due to underground springs. John is involved in assessing the repairs as well as determining if there is a solution to avoid this happening in the future. He also updated the Board on the replacement of light bulbs on our street lights, they came by to work on the fixture at my house on Wednesday and I can tell everyone the difference is remarkable.

Dave Rodgers updated the Board as to the status of a vacancy on the ARB Board, announcing Jerry Hughson will serve on the board, continuing Jerry's tradition of volunteering his intellect and experience in service to our community.

Dan Franck reported ongoing discussions as to whether it is necessary to provide additional rock fill at Holley Lake dam due to runoff and lack of vegetation in certain areas.

Greg Burkes continues his audit of the RV lot to make sure it is safe, sound, and efficient for those who use it. Also he continues to diligently work to bring our new web page to life.

The meeting was adjourned at 4:05PM

Respectfully submitted,

Dan Franck, Secretary

G&S COMPUTING

SOFTWARE | HARDWARE | NETWORKING

803-641-9943 www.gscompinc.com



On-site and Drop-Off Services Available

Common Services Include:

- Malware Removal
- Computer Repair/Upgrades
- Network Setup/Diagnostics
 - Wireless Solutions
 - Device Configuration



37 Capital Drive
Aiken, SC 29803



Cottage Rose Antiques

324 Park Ave. SE Aiken, SC

Next to the Train Station on Park

Downtown Aiken

803-645-0324

A new store with discriminating taste

See us on Facebook

www.facebook.com/cottageroseantiquesaiken

Historic Downtown Aiken - Beautifully Appointed Walkup Furnished Rental with Balcony



This historic 1,200 square foot two bedroom walkup apartment is located in downtown Aiken at the intersection of Park Ave SE and Union Street, next to the Aiken Railroad Depot (Visitors Center and Museum). This comfortable well-appointed apartment is a perfect get-away to visit and enjoy all that Aiken has to offer with walking distances to the shops, restaurants, and stores.

803-645-0324

VRBO.com: #629431



SOLATUBE®

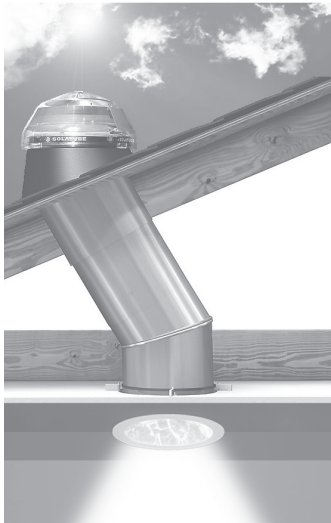

Ideal for:

- Bathrooms
- Hallways
- Closets
- Laundry Rooms
- Dens
- Home Offices
- Kitchens
- Dining Rooms
- Family Rooms



For More Information, Contact:

Brighter Solutions 803.551.1026

www.BrighterSolutionsSC.com

Computerized Engine Analysis
Professional Import and Domestic Auto Service

AUTO TECH, INC.

643-9266

460 Silver Bluff Road
Aiken, SC 29803



Steve Young



Owner



AFFORDABLE

Home Repairs

All Types of Home Improvements

Windows & Doors

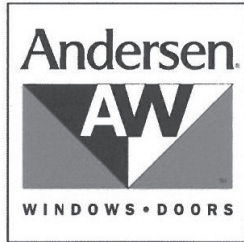

**We Sell, Install & Service
Anderson, Pella & All Major Brands**
Call For A Free In Home Consultation
Today (803) 979-4189
www.affordablescga.com



Fresh Perspectives

Residential and Commercial Cleaning Services
Free Estimates

Licensed, Insured and Bonded

Deborah Birmingham, Owner
Email: housekpr5@aol.com

Serving Aiken Since 2000
(803) 439-6318 Mobile



BCares LLC

Heartfelt Care For Your Loved One

23 Fawnwood Dr E
Aiken, S.C. 29803

Rebecca Campbell
Owner

803-646-7352
bcaresllc@hotmail.com
"No Job Too Small"

Patio, Sunroom, Poolside
We're Your
Relaxed Living Headquarters!

Outdoor/Sunroom Furniture
All-weather wicker
- Hammocks
- Tropical Furnishings,
Wall Art including fun signs
to hang poolside or beside

Polywood Furniture
exclusive Aiken-Augusta dealer
• Most 1 rat, splinter or crack -
completely weatherproof
• Easy to clean material has
solid color throughout
• Substantial and durable outdoor
furniture, 20 yr limited warranty

We Also Carry Fire
Pits And Grills.

WICKER BARN

706.364.3570
wickerbarn.com
3910 Washington Rd, Augusta
(just West of Bobby Jones Expwy)

Trusted Service Since 1967

- Protecting Your Health & Property for Over 47 Years
- Home, Business, and Industry
- Environmentally Responsible

Call Now!
803-649-9803

www.aikenpest.com



All Saints' Anglican Church

Corner of Fairfield St. & Richland Ave.

Dignity of Worship - Tradition - Family
Steadfast Faith - Conservative Values

Services

Sunday: 8:30 a.m. & 10:30 a.m.
Wednesday: 5:30 p.m.

Tel: 803-648-9991 Website: allsaintsaiken.org

TurfArtistry

Locally Owned and Operated

Call Today!

For Your **FREE** No-Obligation Lawn Evaluation
(803) 522-4668

\$30 First Weed Control Visit

*Lawns up to 5000 sq ft

Services Offered

Fertilization-Weed Control-Lawn Insect control-Lawn
Disease Control-Core Aeration-Lime-Tree & Shrub Ferti-
zation, Insect Control and Disease Control

www.turfartistry.com

803.643.2772
Aiken

Al Duffie
owner

compufix
on site service for your computer needs

keeping the connection to your world working

www.compufix1995.com

serving Aiken since 1995

Remodeling~Room Additions~Renovations



Complimentary In Home Consultation

Call the Woodside Experts



Aiken Design Center
at The Village

230 Village Green Boulevard
Aiken, SC 29803
803.617.0919

Enjoy Warmth at the Flick of a Switch!



Having trouble getting your gas logs to light?



If your gas logs aren't working properly, call **Holley Heating & Air** right away for expert **Gas Log Service**. We'll thoroughly inspect and clean your system and fix any problems we find.

Indoors or out, everyone loves the warmth of a fire on the hearth, but not the mess and maintenance of a wood-burning fireplace.

Let **Holley Heating & Air** show you how gas logs and remote controls can **add value, beauty and comfort** to your home. Save now on a wide variety **energy-efficient gas logs** that deliver effortless ambiance so you can cozy up to a roaring fire whenever you like.

Cozy up to a roaring fire with clean, convenient gas logs from

HOLLEY

Heating and Air Conditioning, Inc.

Quality
Service
Since 1909

A name you know. A name you trust.

Call today. (803) 649-6551



Learn more @ www.HolleyHeatingAndAir.com



kendrickbodyshop.com

513 Silver Bluff Rd.
Aiken, SC 29803
803.617.0324

3720 Richland Ave. W.
Aiken, SC 29801
803.649.2676

RETURN ENGAGEMENT

Upscale ladies consignment

Located in the Historic Holley Building—
Downtown Aiken

Free Concierge home visits for estates and large consignments

Hours: 10:30am-5:30pm 803-642-3337
113 Laurens St SW Open consignment on
Suite 106 Aiken, SC Mondays. By Appt T-Sa

www.Returnengagementaiken.com



**FIRST CHOICE
PAINTING INC.**
Licensed • Bonded • Insured
www.firstchoicepainting.com



Phone
(803) 644-3318

Owner
QUINCY HOCHSTETLER



*Evergreen Irrigation, Landscaping
and Lawn Care*

Residential • Commercial

FREE ESTIMATES • SATISFACTION GUARANTEED

Owned and Operated by
CHRIS & DAWN BEAM

(803) 645-7757

**Convenient
Woodside
Location!**

SPORTS PLUS

Physical Therapy

right now!

Immediate Attention. Unmatched Compassion. Amazing Skills.

- Joint Sprains & Strains
- Neck & Back Pain
- Orthopaedic Injury Rehab
- Sports Injury Rehab
- Return to Golf Program
- Post-Operative Treatment
- Total Joint Replacement Rehab
- Injured Worker Rehab
- Auto Accident Injury Treatment



1397 Silver Bluff Road
Aiken, SC 29803
P 803.220.1073
www.csmr.org

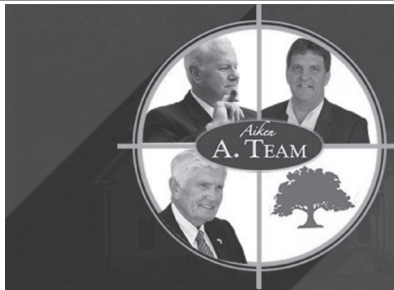

CALL US AT (803) 292 6779

AIKEN'S SPECIAL FORCE
in Residential and Commercial Real Estate

The Number 1 Company for Sold Listings
In Woodside Plantation for 2015



Joe Murphy
803-292-6779
jmurphy@woodside-realty.com

We Sell Houses
Call Us



1419 Silver Bluff Road • Aiken, SC 29803
www.woodside-aiken.com
www.aikenteamrealty.com



Wally Busch
803-640-7978
wbusch@woodside-realty.com

Sunshine

Hand Window Cleaning **Pressure Washing & Window Cleaning**
Roof Stain Removal
Gutter Cleaning
Deck Restoration
Concrete Cleaning

O: (803) 642-6341 • F: (803) 641-0169
 Brent & Brad Chavis

Proudly Serving Woodside for over 15 Years!

KC'S SOUTHERN BLESSING LAWN CARE

We cut costs, not quality.

We offer 100% satisfaction on complete lawn care & landscaping services!
 Guaranteed 20% discount from current service for all new clients!

Residential & Commercial



Proudly Serving the CSRA with:

- Mowing Services
- Tree & Shrub Care
- Edging • Planting • Weeding
- Spring & Fall Clean-Up
- Pressure Washing • Painting
- Complete Storm Clean-Up
- Debris Removal • Sod Installation
- Farm Fence Repair & Painting

Other Services Available Upon Request

Call Today 803-564-6132 or cell 803-260-0602 For Estimate

LAWNS STARTING AT \$30

Carolina Porch Designs

Specializing in...

- All-Season Rooms
- Florida Rooms
- Screen Rooms
- Decks

Gene Wengerd
 (803) 507-4280

Licensed General Contractor - Bonded



NO-FRILLS Painting

Free Estimates • Reasonable Rates
 Licensed & Bonded

Joseph Nirenberg
 Owner

Mobile: (803) 295-1104
 nofrills@comcast.net



ALBRECHT CENTER
for ANIMAL WELFARE

LetLoveLive.org



Adopt

**Shop or Donate to any
of our three Aiken
Thrift Shops!**



Donate

**199 Willow Run Road
Aiken, SC 29801
803-648-6863**



Volunteer

**Clinic Now Open!
Spay/Neuter - Wellness
Vaccinations - Testing**



Pat Roberts

Realtor

803-270-1730

pat.roberts@aikensc.com

Selling Aiken for Over 30 Years

View My Virtual Tours at-

www.aikensc.com



*Woodside Plantation continues to be
in demand. Whether buying or selling,
please give me a call for all of
your real estate needs.*



Aging into Medicare? Shop locally...with Ruby!



- ◆ Offering all major Medicare Supplement Carriers
- ◆ Specializing in Senior Products: Long Term Care, Final Expense, Drug Plans & Medicare Advantage
- ◆ Efficient, confidential and professional
- ◆ Local service!!!

Ruby Masters
803-349-7468

Mark Taylor and Associates, LLC
965 Dougherty Road, SW, Aiken, SC

ASD178925

Howell Printing COMPANY

Since
1867

Located in beautiful downtown Aiken

345 Barnwell Ave, NW

803-649-2545

www.howellprinting.net

We are a locally owned business that offers quality craftsmanship with personal service and will go the extra distance to ensure the highest quality printing.

- Booklets
- Cards
- Banners
- Brochures
- Posters
- Large format

One-stop shop for printing, design, mailing, marketing projects and much more.

Like us on 



Natalia Aldrete
803-357-2616

House Cleaning Services

Affordable Prices



LUCKY QUARLES GUIDE SERVICE

Rick Quarles
803-221-6543



USCG Licensed

A. QUINN TREE EXPERTS

**FREE
ESTIMATES**



- * DANGEROUS TREE REMOVAL
- * CERTIFIED ARBORIST
- * STUMP REMOVAL
- * 40 YEARS EXPERIENCE
- * FULLY INSURED
- * LOCAL REFERENCES AVAILABLE

**SENIOR CITIZENS
DISCOUNTS**

**803-295-2051
770-256-0128**

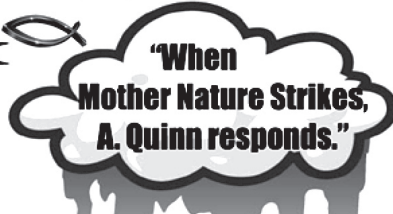

Andrew St.Clair



Home Renovation Specialist

803 221-6709

One Call Does It All
Bathrooms+kitchens+tilework+painting+flooring
19 years servicing fine northern homes
Now a Woodside resident

198 Pink Dogwood Circle **\$305,900**



138 Tall Pine Drive **\$269,000**



206 Pink Dogwood Circle **\$309,000**



649 Burden Lake Road **\$439,000**



110 Eagles Nest Lane **\$209,900**



110 Boxwood Road **\$219,900**



Hurry Home to Woodside



Exceptional homes are waiting in Woodside! Choose one today! OR, build your dream home on one of these specially-priced lots: 140 White Cedar for \$49,900; 123 Longwood Green for \$34,000; 178 Mockernut for \$104,900; 380 West Pleasant Colony for \$39,000; 193 Foxhound Run for \$120,000; 157 Glen Haven Circle for \$25,000; and 590 West Pleasant Colony for \$99,900.

Nancy Cerra, REALTOR® (803) 295-3424 nancy@nancycerra.com

Meybohm
REALTORS®

Aiken's Golf
Community Specialist

Nancy Cerra
Hurry home.

Curb Cuts

Tired of tensing up every time you pull in and out of your driveway?
Worried about damaging your car?



Here to help you with your concrete needs
TT&S Contracting- Scott Powers
803.640.7063



**Material
Things**

Decorative Arts & Design Studio
- Creating Since 1992 -

**TOP 10 REASONS TO USE
MATERIAL THINGS**

- AFFORDABLE PRICES
- EXPERIENCED DESIGNERS
- FABULOUS LIGHTING & LAMPS
- QUALITY LOCAL SEWING & UPHOLSTERY WORKROOMS
- FABRICS, TRIMS, WALL PAPERS, & HARDWARE
- FRIENDLY EMPLOYEES - CREATIVE THINKERS!
- ONE-OF-A-KIND ACCESSORIES/ANTIQUES/FURNITURE
- 8 WAY HAND TIED/KILNDRIED SOFAS & CHAIRS
- LOCATED IN DOWNTOWN AIKEN #DOWNONPARK
- SUCCESSFUL BUSINESS FOR 23 YEARS!

318 Park Ave. SE, Aiken

Mon-Wed. by appt & to the trade • Thurs-Fri. 10-5:30 • Sat. 10-4
(803) 643-3701

materialthingsofaiken.com

Matildawear

Embroidery, Monogramming & Heat Printing

Holiday gifts for children and adults
Animals, Stockings, Vests, T-Shirts, Pajamas and one of kind items
Call to see what we can create for your holiday season

Too many items to list



Go to Etsy.com under shop Matildawear and Like us on Facebook
407-902-1959 or 83-455-0019 located in Beech Island, SC



**PET SITTING by
CAROL**

In WOODSIDE.....

CAROL SCHMIDT

803-270-9589

woodsidecarol44@gmail.com



**HITCHCOCK
HARDWOOD**

HARDWOOD FLOORS AND STAIRS

INSTALL - REFINISH - REPAIR - DEEP CLEAN

WE SPECIALIZE IN OCCUPIED HOMES

- DUST FREE**
- DURABLE LOW ODOR FINISHES**
- DRY TO WALK ON IN 3 HOURS**
- NO NEED TO LEAVE YOUR HOME**

**CALL FOR A FREE ESTIMATE
803-648-7255**

www.HitchcockHardwood.com



Genny Fansmith
Realtor

Cell or Text:
803-617-8039
email:

gfansmith@aol.com

**The Fansmith
Team
Meybohm**
REALTORS*

1070 Silver Bluff Road
Aiken, SC 29803

Direct:
803-644-1739

Fax:
803-649-7897

Toll Free
800-868-5625 x 739



George Fansmith
Realtor

Cell or Text:
803-617-8038
email:

gjfansmith@aol.com

**EASY & QUICK
CAR WASH**

765 Silver Bluff Rd
Aiken, SC 29803

Open 24 Hours
803.295.9075

**FREE VACUUM with Any
Touch Free Automatic Car Wash**

Kennedy Business Services, Inc. ***An IRS Registered Tax Return Preparer***

- ◆ Tax Preparation /Authorized IRS e-file provider
- ◆ Accounting services and payroll preparation
- ◆ Providing personalized service to clients since 1991
- ◆ Consultations at your convenience - in your home or our office
- ◆ Member: National Association of Tax Professionals

Robert P. Kennedy
157 Balsam Lane
(803) 649-3308
rpkenedy29803@yahoo.com



FUSION CAPITAL

Aiken * Charleston * Myrtle Beach



Comprehensive Wealth Management & Financial Planning

Jason M. Mengel, CFP® & Dan Webster, RFC®
821 Richland Ave. W
(803) 644-1214
www.fusioncapital.net



Aiken Pet Sitters
At-home Pet Care in Aiken SC

June Crawford
(803) 648-4599
www.aikenpetsitters.com
info@aikenpetsitters.com
Reliable * Experienced * Insured * Bonded

LEN JOHNSON
Tel 803 439 5201
FREE ESTIMATES

SPECIALIZING IN :
CARPET, UPHOLSTERY, & WINDOW CLEANING

Affordable PRESSURE
WASHING

Driveways • Houses • Pools

Jim Beasley
AffordablePW@yahoo.com

Licensed and Insured
803-292-1775



Dalzell Design Landscaping, Inc.

Landscape Design/Build, Land Planning, and Consulting

Will Dalzell (706) 825-4572

175 Sweetwater Rd. North Augusta, SC 29860

www.dalzelldesignlandscaping.com

Harris
Lawncare
& Landscaping, LLC
706-830-0708
www.Harris-Landscaping.com

Sensible Solutions

House Cleaning Service

Kerri Creamer-Fleck

803 507-1492

Professional Service

Reasonable Rates

Lee Nails

Inside the Aiken Mall next to Belk

(803) 648-1999

Monday-Friday: 10am-9pm Sunday: 12pm-6pm

Managed by:

Tony and Sonya Nguyen

(Woodside Residents)

Cut out this advertisement and present during payment for \$2.00 off your next visit*

*cannot be combined with another offer



2152 Silver Bluff Road
Aiken, SC 29803

- Siding & Fencing
- Custom Kitchens & Bathrooms
- Room Additions/Carports
- Custom Decks & Porches
- Seamless Gutters

Herbert "Skip" Wright, Jr.
644-3006

Mobile 215-3671

www.wrightshomeimp.com



Free Estimates

C & R Tree & Stump Service
Licensed & Insured

CASEY RICHARDSON
(803) 439-6315



Paul Wright

owner

O- 803-644-3006

C- 803-221-5374

Free Delivery with 20 Bale Order!

e-mail: pinestrawbypaul@yahoo.com

2152 Silverbluff Road

Aiken, SC 29803

"Your Yard is Our Priority!"

Long Leaf Pinestraw - Lawn Maintenance

Landscaping - Tractor Work

Ron's Home Repair Service

(No Job Too Small)

803-642-9344

home repairs
painting
power washing
epoxy floor coating

deck staining
shelving
wall papering
lights & fans

Ron Tugya

Woodside Resident

Aiken Backflow Company

www.aikenbackflow.com

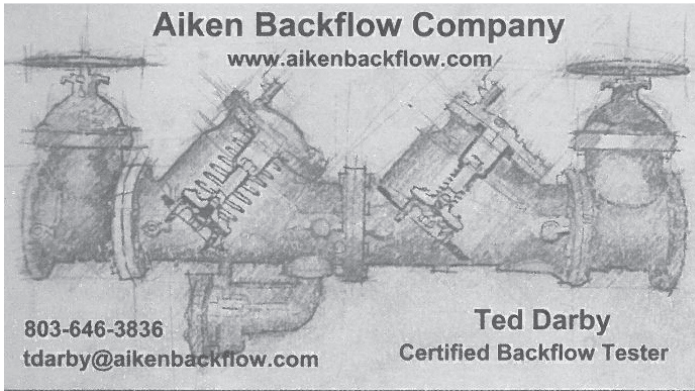

803-646-3836

tdarby@aikenbackflow.com

Ted Darby

Certified Backflow Tester

Take charge of your dream for a confident retirement.

Call me today at 803.641.2192 to get started.



Michael P. Griffin, CFS®, CDFA™

Financial Advisor
Business Financial Advisor

152 Laurens Street NW
Aiken, SC 29801
michael.p.griffin@ampf.com
ameripriseadvisors.com/michael.p.griffin



Ameriprise Financial Services, Inc. Member FINRA and SIPC.
© 2014 Ameriprise Financial, Inc. All rights reserved.

NEED SOME CLARITY ABOUT

your tax and financial wealth?

established. trusted. locally owned.

www.tsgwealth.com

149 Crepe Myrtle Court
Aiken, SC 29803
(803)649-6645



The Smith Group
Tax & Wealth Advisors



Financial Planning and Investment Advisory services are offered through C2P Capital Advisory Groups LLC, D/B/A Prosperity Capital Advisors (PCA) an SEC registered investment adviser with its principal place of business in the State of Ohio. Carl Smith is registered as Investment Advisor Representative of PCA in the states of South Carolina, Georgia, and Louisiana. PCA does not offer tax and/or legal advice.

THREE EASY STEPS...

to a quality roof repair

WE GET TO THE POINT



SOUTH POINT
Roofing & Construction



Tucker
Hawley

Noah
Zook

1

IDENTIFY THE PROBLEM



2

MAKE THE RIGHT CALL



3

PROBLEM SOLVED



SOUTHPOINTCONSTRUCTION.NET | 803.648.9399

Tree Removals
Stump Grinding
Landscaping

Free Local Estimates
Sell Fire Wood



Quality Tree Service Inc.

Residential, Commercial
Licensed, Bonded, Insured
803-663-3278

Owner
Tim George 441-3322 Pg
Cell 803-979-6800

Mailing Address:
128 Pine Hollow Dr.
Aiken, SC 29803



Proudly serving...
Woodside Plantation
& The Village at Woodside

30+ years of combined service
in Woodside Plantation.

Courteous & Professional Staff

On-Time, Reliable Service!



**The
C.A.M. COMPANY
803-522-4028**

- * Superior Lawn Care Practices
- * Pruning, mowing , edging, blowing
- * Irrigation repair and service
- * Pinestraw, mulch applications

*Bryan Sweetnam
Manager*

*Shawn Egel
Asst. Manager*

**THE DEALERSHIP
YOU LOVE TO
DEAL WITH.**



CALL 803-663-3636

CELL 704-609-3403



**REFER
A FRIEND OR
FAMILY AND GET
\$100!!**

YOUR NEIGHBOR

**Travis White
"Magic Sockman"**

**550 Jefferson Davis Hwy,
Warrenville, SC 29851**

UNDER NEW MANAGEMENT

**hondacarsofaiken.com
twhite@hondacarsofaiken.com**

Owned and Operated by
longtime Aiken residents
Wanda (born in Naples),
Cliff & Kirstyn

803 226-0700



Apizza di Napoli

Authentic Neapolitan Wood-Fired Pizzeria
740 Silver Bluff Rd. Aiken, SC 29803

www.apizzadinapoli.com or www.facebook.com/PizzaDiNapoli

Our Pizzaiolos' are Certified by the Verace Pizza Napoletana.
The Italian governing body for quality designations in
making true Italian foods. Only VPN Pizzeria in NC, SC & GA



Beard LAWN CARE

Owner: Steve Beard • 803.641.7404 • 145 Winged Elm Circle
Providing Lawn Care Services to My Residential Community
Call for a FREE consultation today!



VETERINARY HOSPICE
& In-Home Euthanasia

DR. SUNDAY COZZI &
DR. NANCY RODRIGUEZ
(803) 994-9460

Compassionate in-home
end of life care for pets.

www.LapofLove.com
CSRA@LapofLove.com

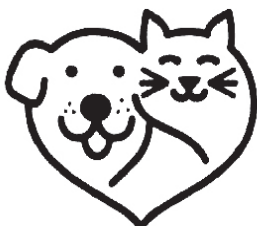

Fur Kidz Pet Sitting

Shirley Wisz
owner

(803) 648-9068 Home
(630) 673-4817 Cell

"I will treat them like my own"
Specializing In Daily, Midday, &
Overnight Pet Care

CRUISEONESM
Dream Vacations *Start Here*

Discover the CruiseOne Difference
Personal Service and the Lowest Price

Why Book Your Next Cruise or Resort
Vacation with Me?

✓ Excellent customer service
on all travel purchases.

✓ Unbiased advice to find the
best vacation for you.

✓ Exclusive pricing and promotions.

Joe Mesimer & Ingrid Graves

INDEPENDENT VACATION SPECIALISTS

Aiken, SC

(803) 649-4108

(888) 805-7447

www.cruiseone.com/jmesimer

CA 2006278-40, FLST 35829, IA 655, WA 601698664, NV 2005-0073. © CruiseOne



WOODSIDE ADVANCED MASSAGE

FEEL WELL / MOVE WELL

Relaxation
Stress Reduction
Fatigue Management
Life Related Injuries

Advanced therapies
for conditions such as
MS, Lupus, Fibromyalgia,
and Lymphedema

Woodside Executive Park
803.522.2296

Tuesday through Saturday by Appointment



Adam's Nursery and Landscaping
"Strong Roots--Steady Growth"

Landscape Design and Installation
Lawn Maintenance
Irrigation Installation or Repairs
One Time Clean ups
Backhoe Work

(803) 259-2538
(803) 300-0896
(803) 259-2326 Fax

adamsnursery.net



210 Curtis Drive Williston SC 29853
adama29853@yahoo.com

Room Additions
Kitchens
Baths



Termite Repair
Windows
and more

J.D. Norris Construction Co., Inc.

"Your Remodeling Specialist"

803-593-4587

www.jdnorrisremodel.com



J. D. & Cheryl Norris - Owners

DreamMaker
Bath & Kitchen
ENHANCING LIVES. IMPROVING HOMES.

803-593-9191
jdn.dm@comcast.net
www.dreammakeraiken.com



**Everett Johnson Roofing
and Construction Co., Inc.**

318 Croft Mill Rd.

Residential and Commercial Roofing
RHETT JOHNSON
Licensed and Insured

Office 803-641-2365 • Fax 803-641-1503

Mobile 803-645-2804 • Email TEJRoofing@aol.com



DAN BROZOWSKI
Moving Consultant

1427 Marvin Griffin Rd.
Augusta, Ga. 30906
T 706-722-7726
800-530-0094

daniel.brozowski@colemanallied.com
www.colemanallied.com



Agent For Allied Van Lines

The Holidays are Here

Reserve Your Date
Early for a Discount

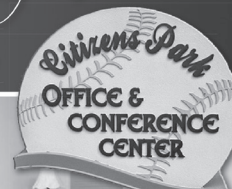

It is Time!!
It is Time To Book Your Holiday Event

Host a Stress Free Holiday Event at Citizens Park Office and Conference Center. The perfect way to celebrate the Holidays and say thank you to Family, Friends, or Staff with a Private Event just for Them.

Book Early



Citizens Park Office and Conference Center
www.Citizensparkocc.com :: 803.226.0504

TURFTEC

LANDSCAPE & DESIGN

Call Today For
Your Free Estimate!
Phone: (803) 292-9597
www.TurfTecLandscape.com

NEW YEAR NEW CLIENT DRIVE

Now taking new clients for:
-Landscape Maintenance
-Fertilization Programs
-Landscape Projects



Join the Greater Aiken Chamber of Commerce as we travel to...

SWITZERLAND | FRANCE | GERMANY | HOLLAND

RHINE RIVER CRUISE



November 2-10, 2016
9 Days | from \$3,599 per person
Roundtrip airfare from Augusta, GA
All inclusive meals, beer and wine
Five star accommodations
Great ports of call
Entertainment, tours and more

Reserve your stateroom now:
Melissa Viola | Aiken Chamber of Commerce
chamber@aikenchamber.net | (803) 641-1111



Pressure Washing & Window Cleaning!

803-439-1867

- ✓ Driveways
- ✓ Gutter Brightening
- ✓ Low Pressure Siding Cleaning
- ✓ Roof Stain Removal
- ✓ Window Cleaning



Woodside Resident
Licensed & Insured



Pressure Washing & Low-Pressure Exterior Cleaning

www.AikenSoftWash.com

UNDER NEW
MANAGEMENT
AND NEW OWNERSHIP

Mario's

ITALIAN KITCHEN

~ Taste us again for the first time. ~

• A WOODSIDE REWARDS EXCLUSIVE OFFER •

20% OFF
THROUGH THE END
OF THE YEAR.

Valid on all purchases during lunch, dinner or carryout.
Excludes alcohol. Not valid with other offers or promotions. Keep and reuse now thru 12/31/15.



The Village at Woodside • 116 Coach Light Way • (803) 226-0190

NEW HOURS: Tuesday-Friday 11am-9pm • Saturday 4pm-9pm • Call ahead seating available • Dine in or Carry out

Hawkins

Irrigation & Repair

Licensed, Bonded & Insured
Free Estimates

Jeff Hawkins, Owner
803.292.5380

- Residential
- Commercial
- Installations
- Modifications
- Repairs

TurfMasters Lawncare

Locally Owned and Operated

Call Today!

For Your **FREE** No-Obligation Lawn Evaluation
(803) 641-1818

Specializing

In the chemical treatment of lawns,
trees, and shrubs

Services Offered

Fertilization-Weed Control-Lawn Insect control-Lawn
Disease Control-Core Aeration-Lime-Tree & Shrub Ferti-
zation, Insect Control and Disease Control

Quality Service From a Neighbor Who Cares

Call today!
(803) 226-0380



Spring-Green Lawn Care

Your local lawn and tree care professionals.

Joe Ferrari, Owner • jferrari@spring-green.net
(803) 226-0380 • www.spring-green.com

WPPOA BOARD OF DIRECTORS

President
Larry Wittenmyer

Vice-President & Common Area Landscaping
Mary Shultz

Secretary, Lakes & Dams
Dan Franck

Treasurer
Lynette Brumfield

Security
Greg Hoffman

Covenants
Linda Rudd

Roadways, Street lights/ Signs, Walking Paths
John Rogers

ARB
Dave Rodgers

Technology, Communications, Facilities and Amenities
Greg Burkes

WPPOA OFFICE

Stephanie Wood, Association Manager

June Carlson

Adrienne Knowles

Trisha Leveille

Michelle Yonce

George Hughes

Roy Blake

Dave Prough



Courtesy of Dave Rodgers